

EVC16 Series of Electric Vehicle AC Power Supply Charger

Installation and Operation Manual

EVC16-AW7KGB2U2(UC)

EVC16-AW11KGB2U2(UC)

EVC16-AW22KGB2U2(UC)

EVC16-AW7KTB2U2(UC)

EVC16-AW11KTB2U2(UC)

EVC16-AW22KTB2U2(UC)



Installation and Operation Manual

V1.0

Copyright Information

All the content presented and picture marks in this manual is the legal copyright of INVT Electric Vehicle Drive Technology(Shenzhen) Co., LTD. Without the authorization of the person in this company, no one shall copy, extract or otherwise use the above content. If you are authorized to use the content in this manual, you must use it within the scope of authorization, and indicate the "source of content". We reserved the right of pursue relevant legal responsibilities if there is any violation of the above statement.

Disclaimer of Warranties and Limitation of Liabilities

The specifications, illustrations and information in this manual are based on the latest data provided by the technician. INVT reserves the right to update manual without timely notice. The information in this manual has been strictly checked for accuracy, but no guarantee is given for the completeness of its content, including but not limited to product specifications, features and illustrations. INVT shall not be liable for any direct, special, incidental or indirect damages or any damages of economic consequence. (Including loss of profits).

IMPORTANT

Before operating or maintaining this charger, please read this manual carefully, paying extra attention to the safety warnings and precautions.

Safety Information

In order to ensure the safety of yourself and others, and to prevent your vehicle and charger damaged, be sure to strictly read and follow the instructions and warning statements in this manual to operate the charger. It's of great importance that the children forbidden to operate this machine. The parents need to monitor the children when they stay around the charger.

DANGER

Indicated the danger information, the operator must avoid these unsafe factors, and operate it according to the local standard . Otherwise, you may get serious injured and other losses.

WARNING

Indicates a potentially harmful situation, you must prevent it from harm yourself by comply with the relevant standards, otherwise it could result in serious injury and losses

Safety Instructions

The following safety warnings covers most of situations that INVT get to know. INVT cannot show or predict or advise you as all of the possible warnings. You must be certain confirm the operation procedure to ensure your personal safety and charger working normally.

SAFETY WARNINGS

- The engineers who install the chargers must have the electrical licensed that meet the requirements of local laws and regulations
- Ensure the chargers are grounded securely and reliably, and the ground connections comply with local standards and criterion.
- Do not install or use this charger near flammable, explosive, harsh, or combustible materials, chemicals or vapors.
- Children should be supervised when around this charger. And forbidden to operate.
- Do not insert fingers or foreign objects into the electric vehicle connector.

- Do not use the charger if the flexible power cord or EV cable is frayed, broken or other damaged.
- Do not use the charger if the enclosure or the EV connector is frayed, broken or other damaged.
- Recommend to use 105°C wire copper conductors (UL1015) .
- Do not operate the charger outside its operating temperature range of -22 to 122 °F (-30 to 50 °C).
- Incorrect installation and testing of the charger could potentially damage the vehicle's battery, components, or charger itself.
- Handle the charger with care during transportation. Do not subject it to strong force or impact or pull to prevent damage to it or other components.

Catalogue

1. About This Manual	4
1.1 Using This Manual	4
1.2 Applicable Areas	4
1.3 Applicable Group	4
1.4 Illustration	5
1.5 How to Use This Manual	5
1.6 General Introduction	5
1.7 Abbreviations and Terms	5
1.8 Product Naming	5
2 Product Overview	7
2.1 External Introduction	7
2.2 Internal Introduction	8
2.3 Appearance Size	8
2.4 LCD Display	9
3. Specifications	10
3.1 Product Name Plate	10
3.2 General Specifications	10
4. Preparation For Installation	13
4.1 General Requirements	13
4.2. Environment and Tool Requirements	13
4.3 Unpack the Charger	13
5. Electrical Installation	14
5.1 Installation Notice	14
5.2 Electrical Installation Procedure	16
5.2.1 Cable Preliminary Treatment	16
5.2.2 Cable Preliminary Installation	17
5.2.3 AC Input Cable Connection	17
5.2.4 Ethernet Cable Connection or 4G card Inlet	18
5.2.5 Front Cove Plate Installation	19
6. Wall and Pedestal Installation	19
6.1 Wall Installation	19
6.1.1 Wall Location Selection	19

6.1.2 Rear Plate Installation	20
6.1.3 Installing the Charger	21
6.1.4 End and Check	22
6.2 Floor Stand Pedestal Installation	22
6.2.1 Construction The Foundation	22
6.2.2 Pedestal Installation	23
7. Power on the Charger	24
7.1 Power on Operation	24
7.2 Charging Operation	25
7.2.1 Connect Charger to EV	25
7.2.2 Start & Stop Charging	25
8.1 Maintenance	26
7.2 Fault diagnosis	26
8. INVT Service	29

1. About This Manual

1.1 Using This Manual

This manual is only applicable to the installation and operation of EVC16 series 7KW,11KW and 22kW AC power supply charger. This manual provides the information required to perform the following work:

- Installation work of the charger.
- Daily fault diagnosis and maintenance of the charger.

Note: This manual may be updated with the product upgrade generation, but the change may not affect the normal reading and execution of the user.

1.2 Applicable Areas

- This manual is applicable to the EU Community countries and other areas that use charging standard IEC61851-1& IEC61851-21-2.

1.3 Applicable Group

- This manual is designed for the qualified engineers with electrical license.
- In addition to being used by professional engineers, users can also strictly follow the process described in this document to perform simple maintenance.

1.4 Illustration

- The illustrations in this document have show most of the product information include some normal functions and typical settings of the product.

1.5 How to Use This Manual

- Ensure that you understand all the contents of this manual is the prerequisite for your correction use . Please read the safety section carefully to ensure that you understand all the safety instructions.

1.6 General Introduction

- The INVT EVC16 series EV charger is designed to charge a electric vehicle or a hybrid plug in electric vehicle at commercial scenario, such as workplace, residential, fleet, underground parking. Our chargers provide you with safe, reliable, fast, and smart charging solutions. The difference between the INVT 7KW, 11KW, 22KW AC EV charger is that the single phase or three phase electrical installation, while the latter 11KW and 22KW support 400V voltage input. The installation procedures for the six models are almost the same.This manual describing the installation steps both single phase and three phase input. This manual will instruct you how to install and use this charger. You can access chargers to the Internet through 4G and Ethernet, control chargers and check running information on your phone APP.

Intended Use

The INVT AC EV charger for commercial scenario is intended for the AC charging of EV. It is intended for both indoor and outdoor use.

Note: The images and illustrations description in this manual may differ slightly from the actual ones

1.7 Abbreviations and Terms

Abbreviations	Definition
AC	Alternating current power supply
DC	Direct current power supply
EMC	Electromagnetic compatibility
EV	Electric vehicle

EVSE	Electric vehicle power supply Charger
RFID	Radio frequency identification
PE	Protective ground
Note: All terms may not be explained in this manual, which may help the engineer understand the operation about the charger.	

1.8 Product Naming

2.1 Model description

EVC	16	—	A	W	22K	G	B	2	U2	UC
a	b	—	c	d	e	f	g	h	i	j

- a: **Electric Vehicle Charger**
- b: **Product series**
- c: **AC charger**
- d: **W--Wall Mounted**
- e: **22kW**
- f: **Charging Gun**
- g: **Business**
- h: **Two Charging Connectors**
- i: **Second Generation**
- J: **European Area**

2 Product Overview

2.1 External Introduction

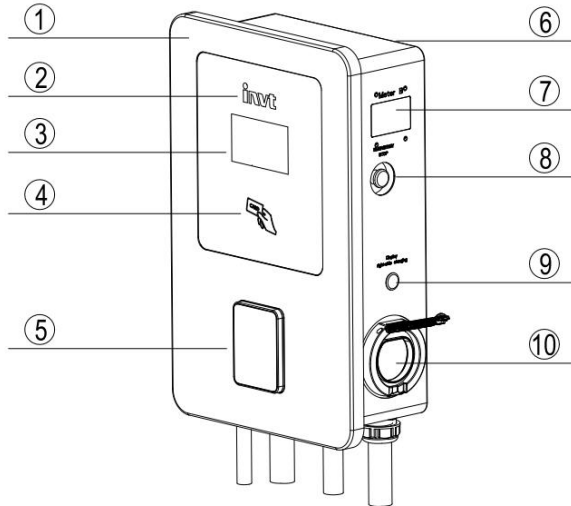

1.Charger Front Cover
2.Manufacturer Logo
3.5 Inch HMI Screen
4.RFID Reader
5.POS Machine(Optional)
6.Charger Bottom Enclosure
7.AC Meter B
8.Emergency Stop Button
9.B Charging Connector Switcher
10.Charger Connector Holder / Charging Socket

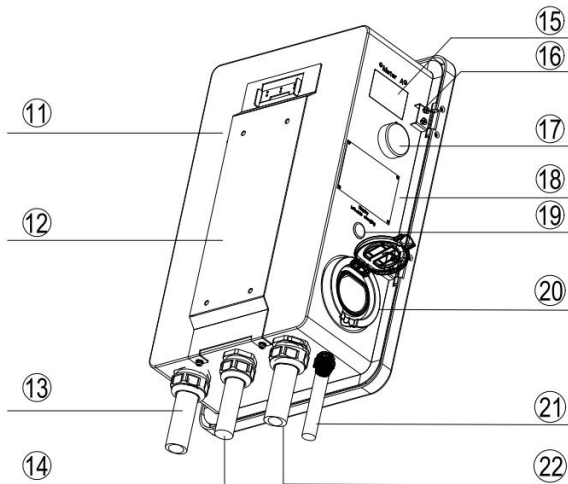

11.Charger Reverse Side
12.Rear Mounting Plate
13.Charging Cable B
14.AC Power Cable Input
15.AC Meter A
16.Hinge For Enclosure
17.4G Antenna
18.Charger Name Plate
19.A Charging Connector Switcher
20.Charger Connector Holder / Charging Socket
21.Ethernet Cable
22.Charging Cable A

Note: The Model EVC16-AW22KTB2U2(UC) is a charging socket version, the device will not equip with the charging cable A and B. For the POS Machine, it's not a standard configuration for EVC 16 series charger but it can be as an option item when INVT clients place an order.

2.2 Internal Introduction

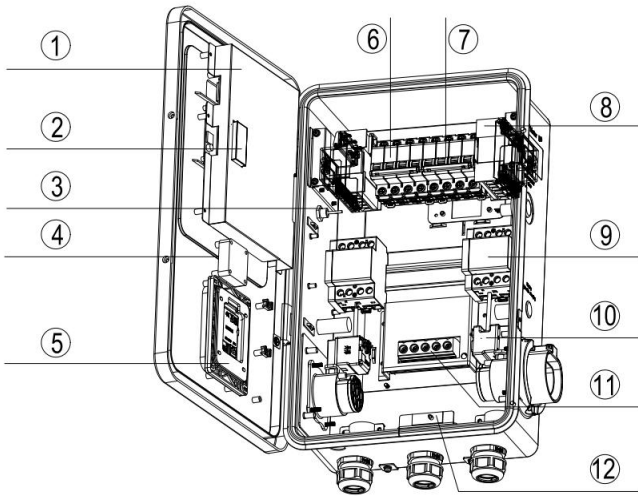

1.	Protection Cover Plate
2.	Charger Controller
3.	Antenna Cable
4.	DC Cooling Fan
5.	POS Machine Mounting Plate
6.	A Connector Circuit Breaker
7.	B Connector Circuit Breaker
8.	AC meter
9.	AC Contractor
10.	Electric Lock
11.	AC Input Connector
12.	Door Open Detection Switch

2.3 Appearance Size

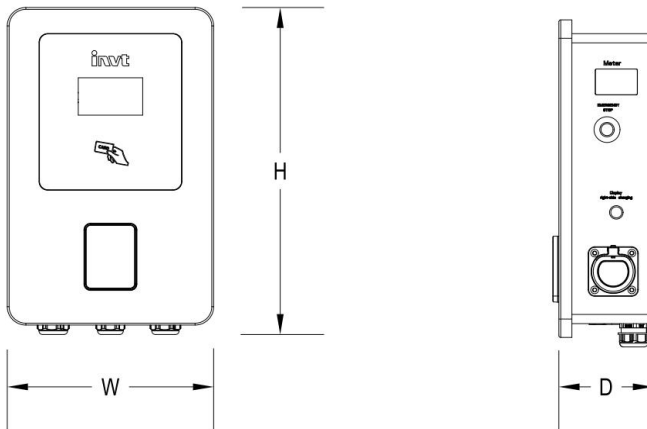

- W Width of the charger
- H Height of the charger
- D Depth of the charger

W: 333 mm H: 533 mm D: 162 mm

Note: The appearance size of all EVC16 series commercial AC model is the same , we use the same enclosure type.

2.4 LCD Display

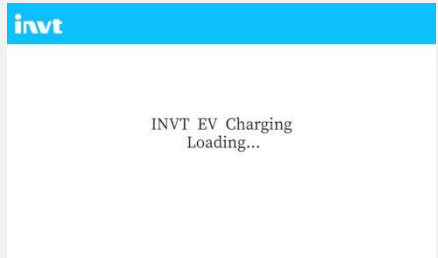
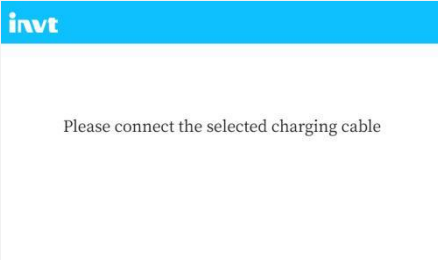
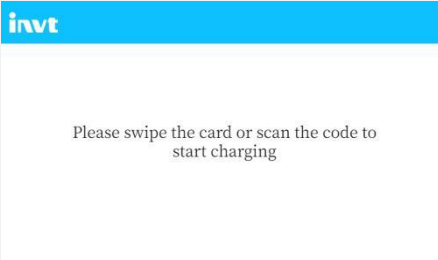
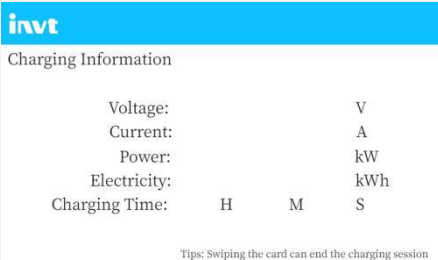
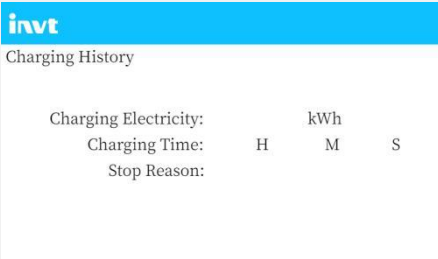
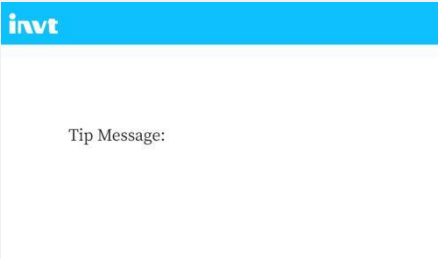
<p>Power on the charger</p>	
<p>Screen tip: Connect the selected charging cable first</p>	
<p>Start a charging session by swipe RFID card or scan the QR code</p>	
<p>Charging session information</p>	
<p>Charging history</p>	
<p>Tips message when charging 1: Charger already reserve 2: Card authorize fail 3: Unknown Id charge, Allow Energy</p>	

Charger error message 1: Background stop 2: Network stop 3: Swipe to stop 4: Vehicle stop	
--	--

3. Specifications

3.1 Product Name Plate

①	invt	AC Charger	⑧
②	Model:EVC16-AW22KTP2U2(UC)		⑨
③	Charging mode:Mode 3		⑩
④	Input AC Power:3P+N+PE Power Frequency:50Hz Input Voltage:400Vac±15% Input Current:2*32A(Max) Rated Power:2*22kW		⑪
⑤	Output Voltage:400Vac±15% Max Output Current:2*32A(Max) Operating Temperature: -30℃~50℃ (More than 50℃ Derating) IP Rating: IP55		⑫
⑥	Serial Number:SNDIN24010001 Date:2024/01 Execution Standard:IEC 61851-1 & IEC 61851-21-2		
⑦	INVT Electric Vehicle Drive Technology (Shenzhen) Co., Ltd. 		

①	Manufacturer LOGO	⑦	Charger Compliance Mark
②	Product model	⑧	Product name
③	Input characteristics	⑨	Charging mode
④	Output characteristics	⑩	Operating temperature
⑤	Charger Execution Standard	⑪	Serial Number and production date
⑥	Company name	-	-

Note: The data in the figure is only a reference and does not represent the physical nameplate of the product. To view the applicable data, find the nameplate on the left side of charger.

3.2 General Specifications

Working Environment					
Parameter	Minimum	Typical	Maximum	Unit	Comment
Operating	-30	25	50	℃	Authenticate within this temperature range

temperature					
Storage temperature	-40	25	85	°C	-
Relative humidity	5	-	95	%	No condensation on the surface
Altitude	0	-	2000	m	-
IP protection level	IP55			/	-

Electrical Parameter								
Model	EVC16-AW 7KGB2U2 (UC)	EVC16-AW 7KTB2U2 (UC)	EVC16-AW 11KGB2U2 (UC)	EVC16-AW 11KTB2U2 (UC)	EVC16-AW 22KGB2U2 (UC)	EVC16-AW 22KTB2U2 (UC)	Comment	
Charging Mode	Mode 3							
EV Connectors	Charging Plug	Charging Socket	Charging Plug	Charging Socket	Charging Plug	Charging Socket	-	
Input Parameters	Input Mode	Single-phase		Three-phase five-wire			Note:TT, TN system.	
	Voltage Range	230Vac±15%		400Vac±15%			-	
	Rated Voltage	230Vac		400Vac				
	Input Frequency	50/60Hz						
	Rated Current	2*32A		2*16A		2*32A		
Output Parameters	Voltage Range	230Vac±15%		400Vac±15%			Note:The output voltage varies with the input voltage.	
	Rated Voltage	230Vac		400Vac				
	Rated Current	2*32A		2*16A		2*32A		-
	Rated Power	2*7.4kW		2*11kW		2*22kW		
Power Factor	≥0.99						Rating condition	
Efficiency	≥99.5%						Rating condition	
Standby power Consumption	≤5 W						-	
Energy Metering	Metering : 0.25~5(65)A;Level 1.0; Build-in MID Certified meter						-	

Circuit Breaker	Type A RCD 40A(Single-phase) (External Installation)	Type A RCD 20A(Three-phase) (External Installation)	Type A RCD 40A(Three-phase) (External Installation)	External connection				
Residual Current Detection	AC 30mA + DC 6mA							
Protective Function	Over current,Over voltage,Under voltage, Integrated surge protection, PME (UK)			-				
Input Connector	3 Pin terminal		5 Pin terminal		Note:8 ~10AWG.			
Connector Type	Qty	two				-		
	Mode	5m	No cable outlet	5m	No cable outlet	5m	No cable outlet	-
	Type	IEC 62196-1 & IEC 62196-2				-		
Insulation Resistance	Input to Output	In the environment of relative humidity ≤ 90% and under normal atmospheric pressure, the insulation resistance between each live circuit and between the live circuits and the ground is not less than 10MΩ at AC 1000V+2Un voltage.				-		
	Input to PE							
	Output to PE							
Withstand Voltage	Input to Output	AC2500V/1min/10mA				-		
	Input to PE	AC2500V/1min/10mA				-		
	Output to PE	AC2500V/1min/10mA				-		
	Leakage Current	<5mA (230Vac/400Vac、 50/60Hz input)				-		

System Parameters

Model	EVC16-AW 7KGB2U2 (UC)	EVC16-AW 7KTB2U2 (UC)	EVC16-AW 11KGB2U2 (UC)	EVC16-AW 11KTB2U2 (UC)	EVC16-AW 22KGB2U2 (UC)	EVC16-AW 22KTB2U2 (UC)	Comment
Display Screen	5.0-inch, 800*480 pixels resolution, 262K colors, IPS-TFT-LCD						
Shell Material	Metal plate Galvanize Plate						
Panel Material	Aluminium alloy+Stalinite						
Appearance Size	333*533*162 mm						
Connectivity Function	4G, Wi-Fi, Bluetooth, Ethernet, RFID customer-specified: POS						-
Communication Protocols	OCPP 1.6J (Can be upgraded OCPP 2.0.1 later)						-
User Authentication	APP, RFID card, Credit Card (Optional)						-
RFID Reader	ISO 15693 and ISO 14443						-
Safety Standards	IEC 61851-1, IEC 62311, IEC 62479, IEC 62955						-
EMC Standards	EN61000-4-2;N-61000-4-6;N-61000-4-3;N-61000-4-12;EN/IEC 61851-21-2						-

EMC Class Level	Class B						-
Execution Standard	See Schedule B for details						-
Certification	CE (TUV),UKCA						
Cool-down Method	Natural cooling			Fan cooling		Fan cooling	
Application	Indoor and outdoor parking station						-
Weight(Kg)	16	15	17	16	18	16	Note:Net weight
Installation	Wall-mounted or floor using a pedestal						-
Accessories List	1. Charger; 2. User manual; 3. Factory test report; 4. RFID card; 5. Support rear plate 6. Screws						-
Note: Three-phase products are also suitable for single-phase, but the power is reduced by two thirds.							

4. Preparation For Installation

4.1 General Requirements

- Obtain permission to install this charger in accordance with local regulations.
- The AC power supply is available at the installation position.
- Make sure cur off the the cable power during installation.





4.2. Environment and Tool Requirements

Prepare before installation:

- Search and clean out a suitable installation location.
- Ensure that the installation location has a walls to install this charger. The bearing capacity of expansion bolts used to secure the rear plate should not be less than 20kg.
- In addition to the above, you may also need to prepare the following tools : Drilling machine, Wire stripper, Crimping pliers,insulation tape, pipe terminals, etc.

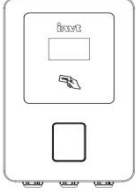
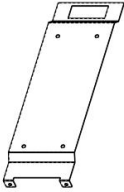
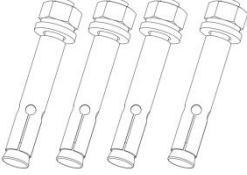
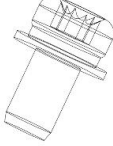
4.3 Unpack the Charger

- Unpack the charger packing case.
 - Take the Charger out of the packing case.
 - Take out the packing materials and installation accessories then put them aside.
 - Check whether the charger and installation parts are damaged. Contact the manufacturer's local supplier representative or after-sales service if it damage or parts
 - Check all parts to ensure that all materials have been delivered.
- EV Charger; b. RFID card; c. User Manual; d. Wall Dock; e. Screws and wall Anchor.

EV Charger		Wall Dock	
Expansion Bolt (M6 x 50) 4 PCS		Screw (M5 x 10) 2 PCS	
User Manual		RFID Card	
Screwdriver (Type T10)		Screwdriver (Type T25)	

5. Electrical Installation

5.1 Installation Notice

1) Electrical device should be installed, operated, serviced, and maintained only by qualified personnel. No responsibility is assumed by the manufacturer for any consequences arising out of the use of this device.

A qualified person is one who has skills and knowledge related to the construction, installation and operation of device and who has received safety training to recognize and avoid the hazards involved.

All applicable local, regional, and national regulations must be respected when installing, repairing, and maintaining this device.

2) Before operating the electrical installation, ensure you have understand the following electrical rules:

- For the 7kW charger model, it is suitable for 230VAC single-phase input,the input terminal definition and the cable diameter requirement please check the following diagram:

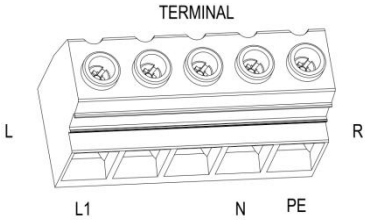
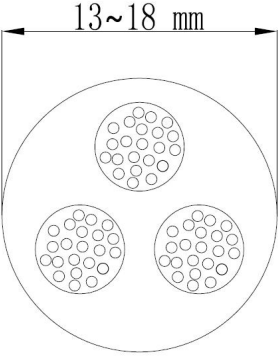
Wiring Terminal Definition	Cable Requirement
	

Note: 1. For 7kW charger, the maximum continuous working current is 32A, and the cable diameter should meet the above requirements. It is recommended to use the 10 AWG cable with 600Vac withstand voltage. Of course, you can also choose a larger size of the cable.

2. The power cable can be use with sheath, but its maximum allowable diameter should not exceed the range shown in the above diagram, otherwise the assembly can not be completed.

- For the 11kW/22kW charger models, they are suitable for 400 VAC three-phase AC power input(TN):

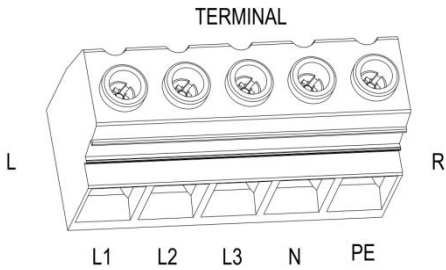
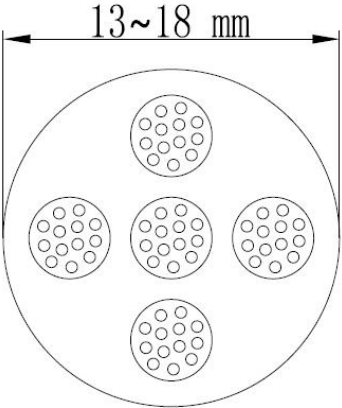
Wiring Terminal Definition	General Requirement
	

Note: 1. For the 11kW charger, the maximum continuous working current is 16A, and the cable should meet the above requirements. It is recommended to use the 12 AWG cable with 600Vac withstand voltage.

2. For the 22kW charger, the maximum continuous working current is 32A, and the cable shall meet the above requirements. It is recommended to use a 10 AWG cable with 600Vac withstand voltage. Of

course, you can also choose a larger size of the cable.

3. The power cable can be use with sheath, but its maximum allowable diameter should not exceed the range shown in the above diagram, otherwise the assembly can not be completed..

5.2 Electrical Installation Procedure

Since the power cable inlet is from the bottom of the charger and electrical connection operation must be open the front cover plate, the power cable installation work should be completed before the mechanical installation.

Note: The circuit breaker (Include RCD) need to be install external on the charger power input cable

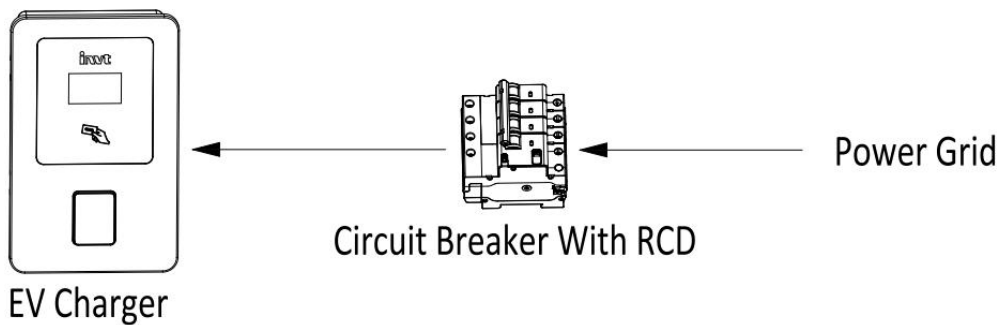

5.2.1 Cable Preliminary Treatment

Measure the demand length of the AC power cable according to the installation location of the charger, and preliminary treatment the cable (If possible, crimp the cable with a tubular terminal for subsequent connection) for preparation.

- Remove the screws of front cover plate by using a screwdriver and put them aside with a storage box.

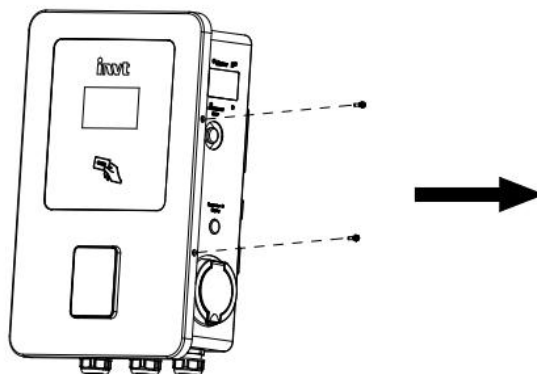

- Open the front cover plate with the direction right to left, please refer to the following picture.

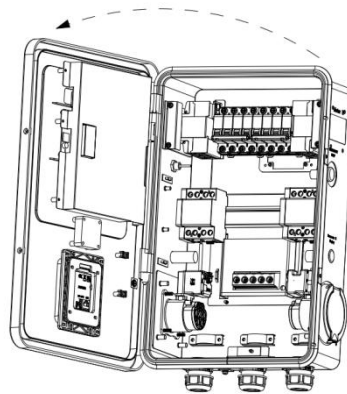

Note: Be sure not to discard the related screws or other parts after open the front cover plate, and the engineer should be careful of other foreign matters into the charger, otherwise it will be difficult to clean up and may be affected the service life.

5.2.2 Cable Preliminary Installation

- Unscrew the waterproof jacket of the cable by turning it counterclockwise.
- Insert the preliminary treatment cable into the waterproof jacket. Reserve the cable length around 10~15mm based on the installation position for easy access to the terminal. (**Note: Crimp the cable to a tubular terminal is necessary for safety connection**)
- Tighten the waterproof jacket by turning a counterclockwise direction.

Loosen the cable waterproof jacket	Cable and waterproof jacket installation
<p>Loosen</p>	<p>Note: Crimp the cable to tubular terminal for safety connection</p> <p>Cable</p> <p>Sheath</p> <p>Screw on</p>

5.2.3 AC Input Cable Connection

- Unscrew the wiring terminal fixing screws by using a screwdriver.
- Connect the cable to the corresponding terminal port. See follow installation diagram for details.
- Using a screwdriver to tighten the screws with a correct torque. (Recommended torque : Max 2 N.m / 10.6 Lbf. in)

- Check the cable after finishing connection: pull the cable with a little force if the cable is not pulled out then connection is well.

AC input cable wiring diagram for single-phase	AC input cable wiring diagram for three-phase
<p>Note: 1. In addition to identify the AC input cable connection by above pictures, engineers can also distinguish the wiring sequence by the print on the circuit board.</p> <p>2. Before connecting the AC input cable to the power grid network, please complete the mechanical installation of the charger first in order to ensure safety.</p>	

5.2.4 Ethernet Cable Connection or 4G card Inlet

There are two ways to connect the charger online, one is Ethernet connection, and the other one is insert a 4G SIM card. You can choose one of the ways to make the charger online depending on the application scenario of the charger.

- For Ethernet cable preliminary treatment, please refer to the section 5.2.2. For Ethernet cable connections, please refer to the following picture.

Note:

Since the diameter of the plastic circular sheath of the waterproof joint is small, so that it can not be directly placed on Ethernet cable, we will make a cutting treatment before delivery, the user does not need to re-crimp the RJ45 connector.

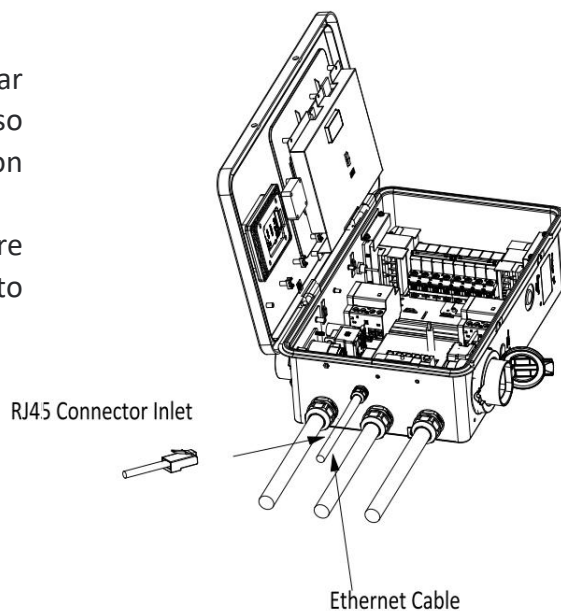

- 4G SIM card insert process, please refer to the following pictures.

4G Card Slot

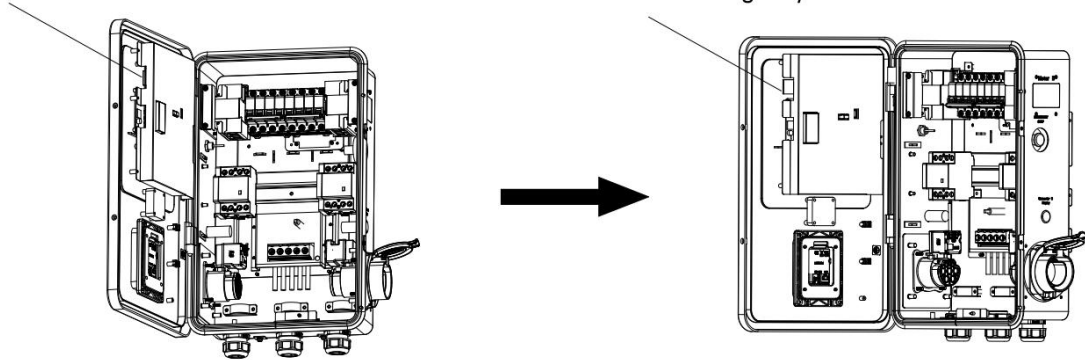

5.2.5 Front Cove Plate Installation

- Clean up the sundries left inside the charger after the AC input cable was installed.
- Check the AC power cable connection again and make sure all terminal connections are correct.
- Reinstall the front cover plate, and tighten the fixing screws by using a screwdriver.

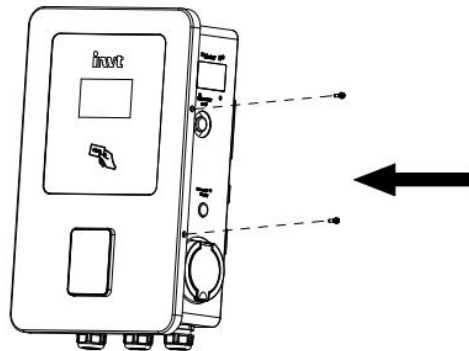

6. Wall and Pedestal Installation

The installation methods of the product include pedestal installation, wall installation,

6.1 Wall Installation

6.1.1 Wall Location Selection

The steps for wall installation are as follows

1. Engineer / user shall prepare 4 expansion bolts (M6 x 50) that it can support the weight over 20Kg.
2. See the detailed requirement of installation space as follows:

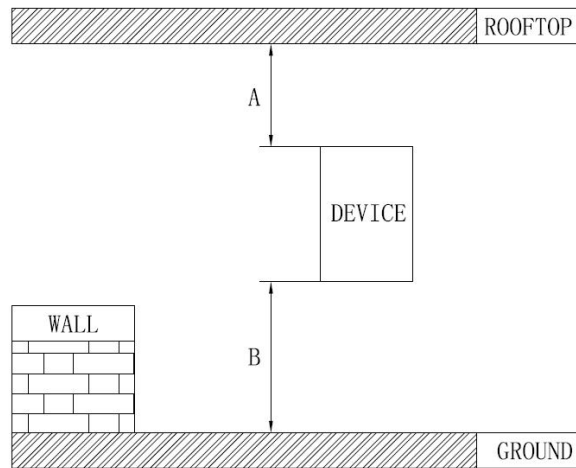

Dimension Suggestion for Wall Installation:

Parameter	Recommended Specification (mm)
A	≥300
B(Indoor installation)	≥900
B (Outdoor installation)	≥1300
Note: The range of installation size can be selected according to local regulatory requirements or actual installation conditions of the location.	

6.1.2 Rear Plate Installation

After selecting the wall location , drill the holes on the wall, and the holes aperture should be suitable for the M6 x 50 type expansion bolt . Fixing the installation rear plate to the wall with the expansion bolt.

After installing the rear plate, check whether the rear plate is properly installed. Ensure that it is not loose.

Rear Mounting Plate	Installation Size(mm)

Installation Schematic Diagram for Wall Mounting

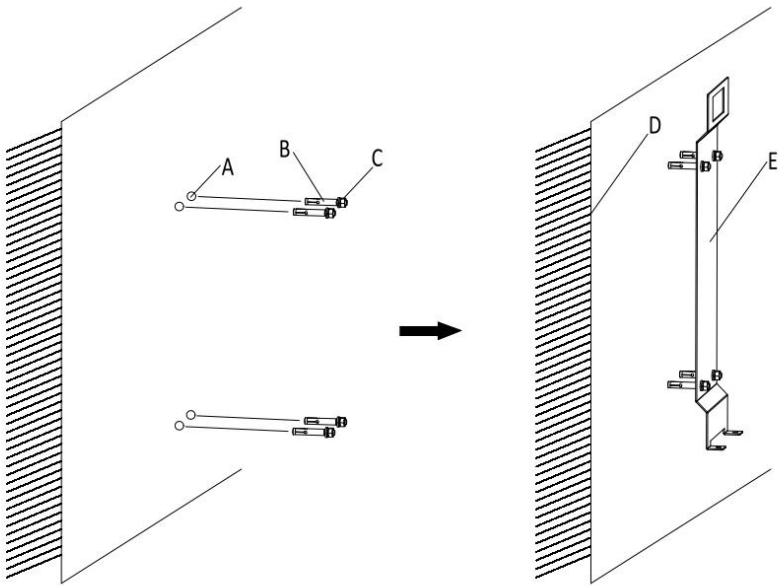

A	Wall Installation Hole
B	Expansion Bolt
C	Fixing Nut
D	Wall for Installation
E	Rear Mounting Plate

6.1.3 Installing the Charger

Installing the charger into the rear mounting plate from top to bottom according to the relationship between the plate and the mounting holes . Use a screwdriver to fixing the mounting bracket to the place where they are connected to the rear plate.

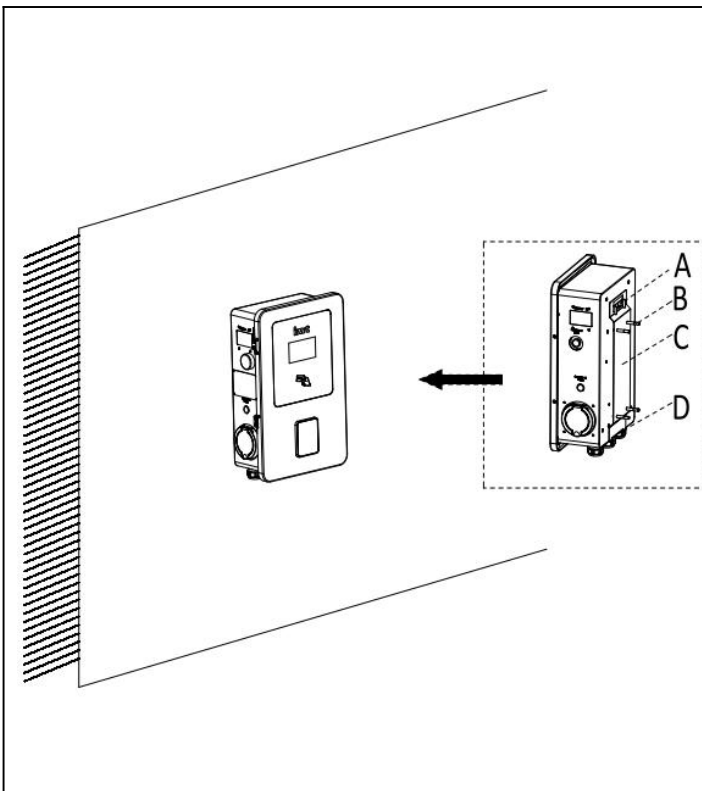

A	Mounting Bracket
B	Expansion Bolt
C	Rear Mounting Plate
D	Bottom Screw Lock the Mounting Plate

6.1.4 End and Check

After finish installing with the above steps, you also need to do a site cleaning: The site debris, garbage and charger outsourcing boxes shall be discarded in a correct way after the installation, the factory test report, use manual and user RFID card shall be properly kept by the user.

6.2 Floor Stand Pedestal Installation

6.2.1 Construction The Foundation

- (1) Pour the concrete foundation with strength level C30 or above.
- (2) Drill and tap 4 holes (M14) in the foundation at the indicated position (H), depth over 100mm. Per install 4-M14 expansion bolts into the holes.
- (3) Make a hole on the foundation with the dimensions specified on the diagram. Make sure that the cables come out of the floor within the marked area of PVC tube.
- (4) Make sure the cable conduit is pre-embedded in the foundation.
- (5) Make sure that a cable length of one meter is available above the foundation for internal routine in the cabinet

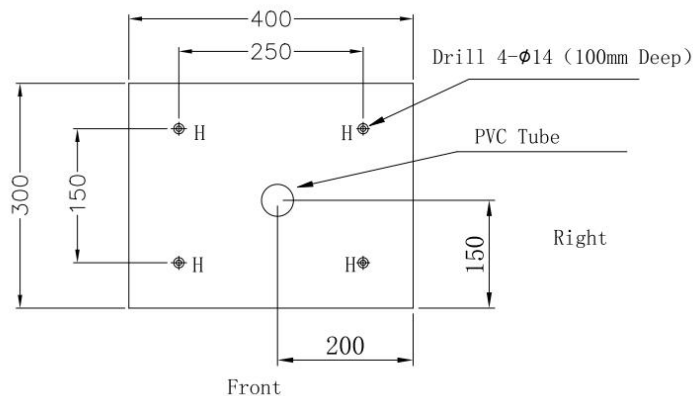
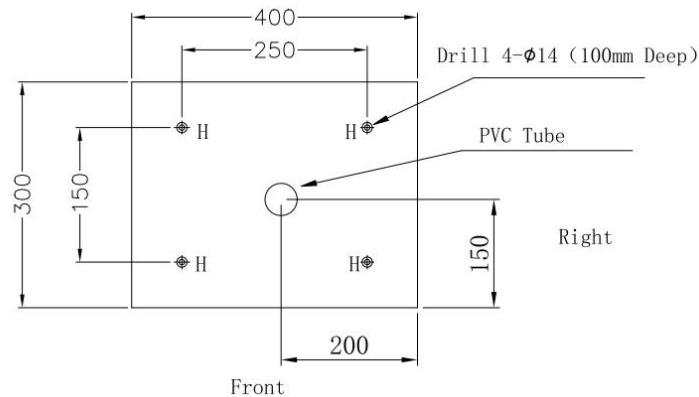

- The diagram is only a schematic of the ground mounting hole and the inlet/outlet hole position.
- The civil foundation should be adjusted by the construction team according to the actual situation.
- Fill the foundation with gravel or shingles to prevent rodents from entering the charger

6.2.2 Pedestal Installation

Network cable and power supply cable go through the inner space of floor-stand pedestal. Install the floor stand pedestal on the ground position against the center line of parking place and fix it by mounting the four screws at the bottom.

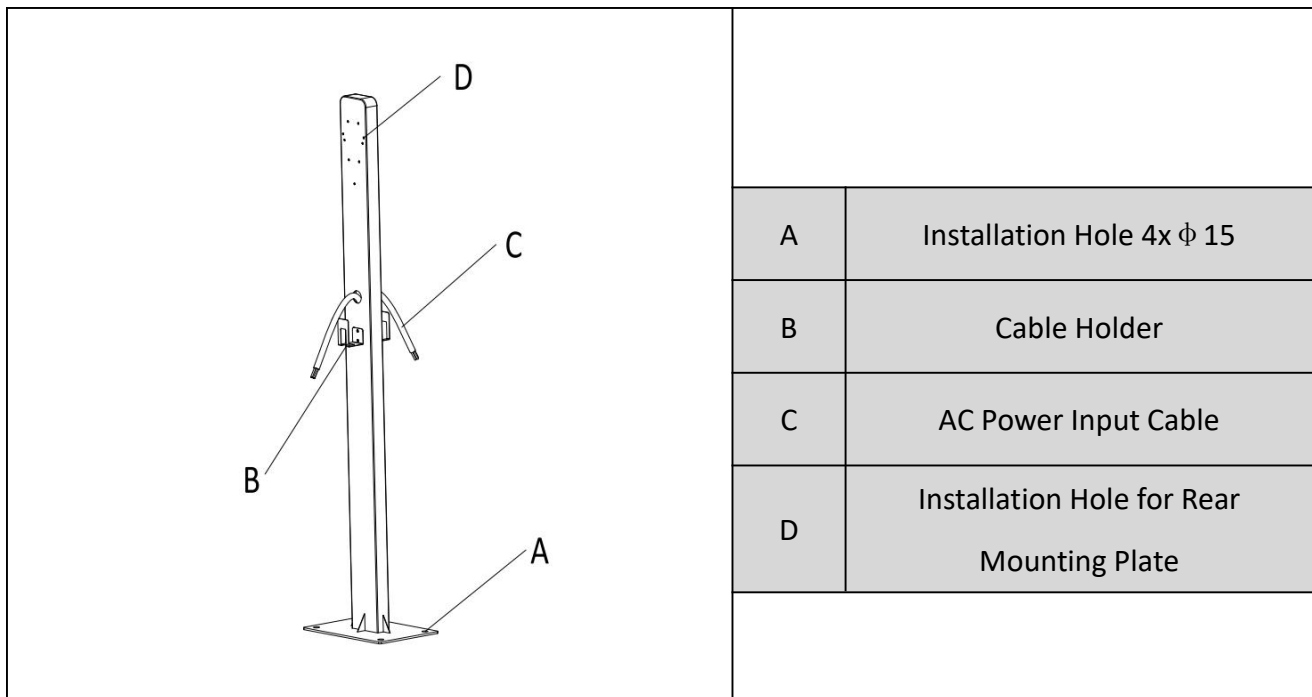

Installing the rear mounting plate, please refer to the step of 6.1.2. Engineer / user shall prepare 4 Fixing screws (M4 x 10) that it can support the weight over 20Kg.

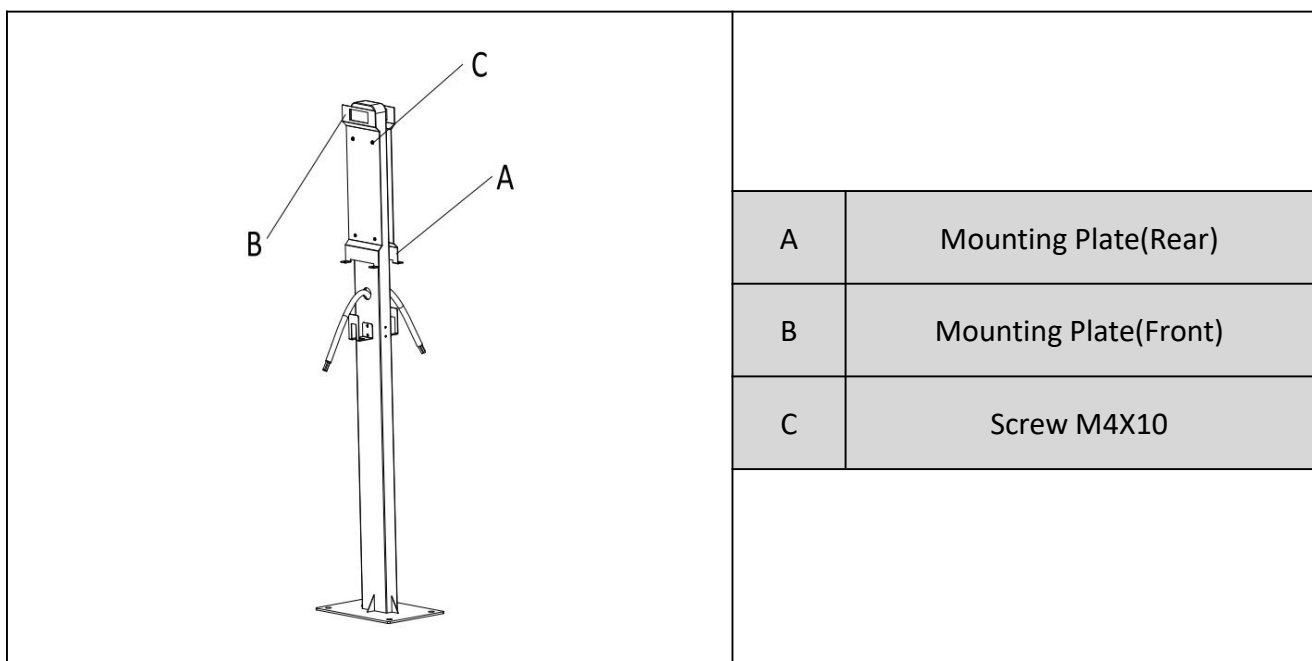

Put the charger on top of the pedestal, install the charger with rear mounting plate, the steps please refer to the chapter 6.1.3

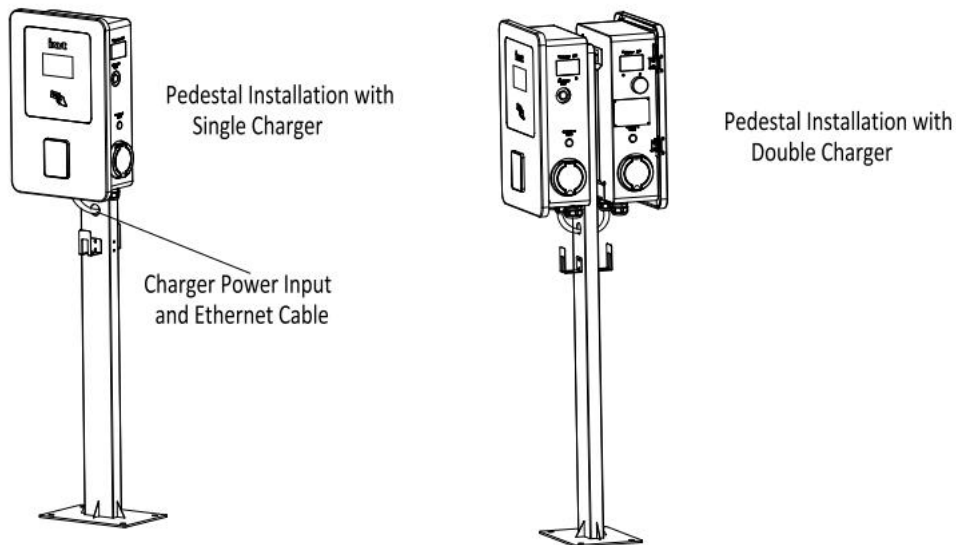

7. Power on the Charger

7.1 Power on Operation

If the network is successfully connected, the icon on the LCD screen will display the online connection, as shown in the following picture.

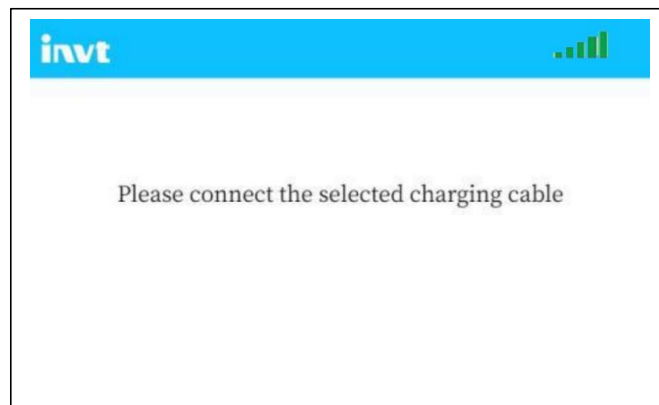

Before powered on the charger, the following work should be completed.

- Ensure that the procedures for charger installation have been executed correctly.
- Check the electrical wires if it have leakage or wrong connection to avoid electric shock accidents.
- Ensure safety, it is recommended to powered on the charger accompanied by electrical engineers.
- Connect the input cable to AC power supply network.
- Turn on the circuit breaker (Include RCD), the screen will display the initially interface.

7.2 Charging Operation

7.2.1 Connect Charger to EV

Park EV near to the charger, take out the charging cable from EV(If it's a socket model), and plug its guns respectively into the socket of the charger and the EV. After plug-in, please check the gun is correctly and tightly connected. with appropriate connection, the charger screens will display "Please Swipe the Card or Scan the Code to Start Charging", which indicates that the charger is ready for charging.

7.2.2 Start & Stop Charging

After the charger is connected to EV and ready for charging, swipe the RFID card for once on the identification area of front panel or scan QR code on LCD screen with APP, then the charging will start. When the charging starts, the gun will be locked on the charger socket. The charger screen will display the running information on the screen, such as charged electricity, charged time, voltage, current and power.

The charging procedure as follows

- 1: Search and Download the charging APP from Google Play or App store. The name: EOSVOLT
- 2: Binding the RFID card number with EOSVOLT app.
- 3: Plug the charging connector to charger and electrical vehicle.
- 4: The screen will shows "Please selected the selected charging cable", then you will need press the button at the side of the charger, as follow pictures. (If your charger equip with only one connector , then you don't need to press this button, plug the connector, the UI screen interface will show to next page)

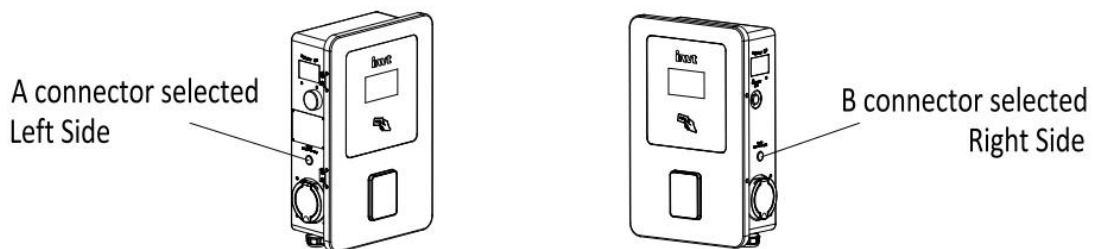

5-1: Start charge by swiping RFID card on charger identification area

5-2: Scan the QR code with APP on charger LCD screen, then click to start the charge.

When the EV is fully charged, the charging UI screen will shows the charging session have finish and display the relative parameters information.

The charger will unlock the connector on this four conditions, Charger faulty, Swiping the RFID card, unplug the connector near the EV, APP operation. In charging state before the EV is fully charged, the user can also stop charging by scanning the RFID card for a second time. The charging session will end and the connector on the charger side will be unlocked.

8. Maintenance and Fault Diagnosis

8.1 Maintenance

Users shall conduct maintenance inspection of the charger, including the following items:

- Check whether the charger power supply cable and charging gun cable/cable is damaged.
- Check whether the charger shell is damaged. If it have vital damage, stop to use it immediately
- Regularly check whether the residual current device function:

This item should be checked monthly if it's possible.

Press the "T" key of the circuit breaker, the protector will trip disconnected under normal function; if not trip normally, see the forward chapter for details solutions.

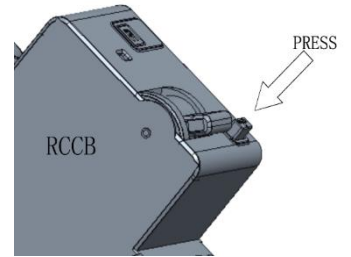

7.2 Fault diagnosis

The following troubleshooting table can be used to check the common faults in the routine maintenance.

Fault	Description	Solutions
Charger not started	The external residual current device is not switch on	Switch on the residual current device
	Wrong phase sequence wiring	Check AC wiring connection

Charger overload and disconnection	Electric vehicle side overload	<ol style="list-style-type: none"> 1. Check whether the vehicle load matches the charger. 2. Check and connect the charging cables of electric vehicles. 3. Correctly connect the electric vehicle charging cable.
Input under voltage or over voltage	AC power supply not correct	Check whether the charger need single phase or three phase connection.
Charger overheats and circuit breaker cut off frequently	The ambient temperature exceeds the Charger operating temperature range	<ol style="list-style-type: none"> 1. Check the working temperature on the charger nameplate. 3. The charger shall be installed in a place with normal temperature or good ventilation conditions. 4. If the problem still open, please stop using the charger and contact the manufacturer's local representative or after-sales service point.
Circuit breaker cut off frequently when charger working	External Residual current device have a fault	<ol style="list-style-type: none"> 1. Replace the external residual current device of the same specification. 2. If the problem still open, please stop using the charger and contact the manufacturer's local representative or after-sales service point.
	Residual current in the charging power supply network	<ol style="list-style-type: none"> 1. Check whether the AC power supply at the front end of the network is grounded properly. 2. Install the Charger grounding conductor .

Fault problem	Possibility	Solutions
charger "ground fault"	Charger failed to ground properly	<ol style="list-style-type: none"> 1. Check whether the electrical ground cable of the charger is correct. 2. Install the protection ground cable correctly. 3. Install the ground conductor for the power supply network.
The Charger failure red LED is always on	The charger emergency stop button is pressed	<ol style="list-style-type: none"> 1. Reset emergency stop button . 2. If the problem still cannot open, please stop using the charger and contact the manufacturer's local representative or after-sales service point.
Vehicle connection was abnormal or the authorization process failed	Electric vehicle charging cable is faulty	<ol style="list-style-type: none"> 1. Check whether the electric vehicle charging cable is normal. 2. Replaced charging cable for electric vehicles when necessary.
	RFID card disabled	<ol style="list-style-type: none"> 1. Make sure that the RFID card is provided by the manufacturer. 2. Make sure that the RFID card is properly registered and available. 3. If the RFID card disabled, please contact the manufacturer's local representative or after-sales service point to obtain a new RFID card. 4. Restart the charger may resolve this failure.
Charger no network connection"	There is no Ethernet or 4G signal	Check the Ethernet or 4G signal at the charger installation site to ensure that the charger is within the coverage of the WIFI LAN.
	The connection between the charger and the router is	Connect the charger to the WIFI LAN manually.

	interrupted	
--	-------------	--

8. INVT Service

If you have any questions about the product, please contact the manufacturer's local supplier representative or the manufacturer's after-sales service. When seeking information or applying for service support, please provide the following information:

- Nameplate information of the charger.
- Warning error message code or name of product charger (can be viewed through APP).

Our company provides customers with a full range of technical support, customers can contact the local office or customer service center hotline.

INVT Electric Vehicle Drive Technology(Shenzhen) Co., LTD

Address: 3F, Bldg B, INVT Guangming Technology Building, Songbai Road, Matian Street, Guangming District, Shenzhen.

contact us

E-mail: tecsup@inv.com.cn

www.inv-ev.com

Customer service hotline: 0086 755 23535207

